



**A LEADER...  
NOT A FOLLOWER!**

MANUFACTURER OF TRAFFIC-,  
CRASH- AND LED LIGHTING SYSTEMS

**VERDIEGRO®**

**VERDEGRO<sup>®</sup>**  
USA

**Verdegro USA LLC**  
888 Biscayne Blvd., Suite 505  
Miami, FL 33132. USA  
T: +1 (786)-408-5709  
F: +1 (786)-431-3097  
[sales@verdegro.com](mailto:sales@verdegro.com)

**VERDEGRO<sup>®</sup>**

**Verdegro Group**  
Munnikenheiweg 59  
4879 NE, Etten Leur.  
The Netherlands  
T: +31 (0)76 - 50 17 990  
[info@verdegro.com](mailto:info@verdegro.com)



+31 (0)76 - 50 17 990  
+1 (786)-408-5709

[SALES@VERDEGRO.COM](mailto:SALES@VERDEGRO.COM)  
[WWW.BLADE-TMA.COM](http://WWW.BLADE-TMA.COM)  
[WWW.VERDEGRO.COM](http://WWW.VERDEGRO.COM)

OR SEARCH FOR YOUR PREFERRED  
DEALER AT OUR WEBSITE  
[WWW.VERDEGRO.COM/DISTRIBUTORS](http://WWW.VERDEGRO.COM/DISTRIBUTORS)

WORLD  
WIDE MARKET

YOUR PREFERRED DEALER

VERDEGRO  
IS A PROUD  
MEMBER OF



# CONTENT

INTRO	2
ABOUT VERDEGRO	5
OVERVIEW	6

## LIGHTING

INTRO LIGHT	12
OVERVIEW	13
HYBRID LED LIGHT TOWER TRAILER	14
HYBRID LED LIGHT TOWER BUCKET	16
LED LIGHT TOWER TRAILER	18
LED LIGHT TOWER UNIT	20

## CRASH

INTRO CRASH	24
OVERVIEW	25
BLADE - TRUCK MOUNTED ATTENUATOR	26
BLADE TRAILER TRUCK MOUNTED ATTENUATOR	27
LIGHT TRUCK MOUNTED ATTENUATOR	28
TRAILER TRUCK MOUNTED ATTENUATOR	30
TRUCK MOUNTED ATTENUATOR-US	32
TRUCK MOUNTED ATTENUATOR-EU	34
OPTIONAL ARROW BOARD FOR TMA	36
RED X LIGHT BOARD	38

## TRAFFIC

INTRO TRAFFIC	42
OVERVIEW	43
SOLAR MESSAGE TRAILER	44
MOBILE VARIABLE MESSAGE SIGNS	46
ARROW TRAILERS	48
SOLAR MESSAGE UNIT	50
MOBILE LANE SIGNALING	52
RIS SYSTEM	54
RUMBLE MAT LAYER	56
AUTO CONE	58
PICK & PLACE TMA ARROW WARNING UNIT	60
COLOR OPTIONS	64
GOODIES	66

## BLADE

INTRO	68
-------	----

# ABOUT VERDEGRO

**2003**  
Founded

**2004**  
First solar power LED arrowboard trailer.

**2005**  
Introduction of the TMA-EU.

**2008**  
Moved to current headoffice

**2009**  
New crash test facility opened

**2009**  
Launched the new MLS

**2012**  
The TMA-US was launched acc. NCHRP 350 TL-3

**2013**  
The Light TMA was launched acc. NCHRP 350 TL-2

**2014**  
Introduction Hybrid Light Towers

**2016**  
The BLADE was launched acc. MASH

**2017**  
Verdegro USA LLC

**2017**  
New production facility

**2018/2019**  
Introduction of the BLADE trailer

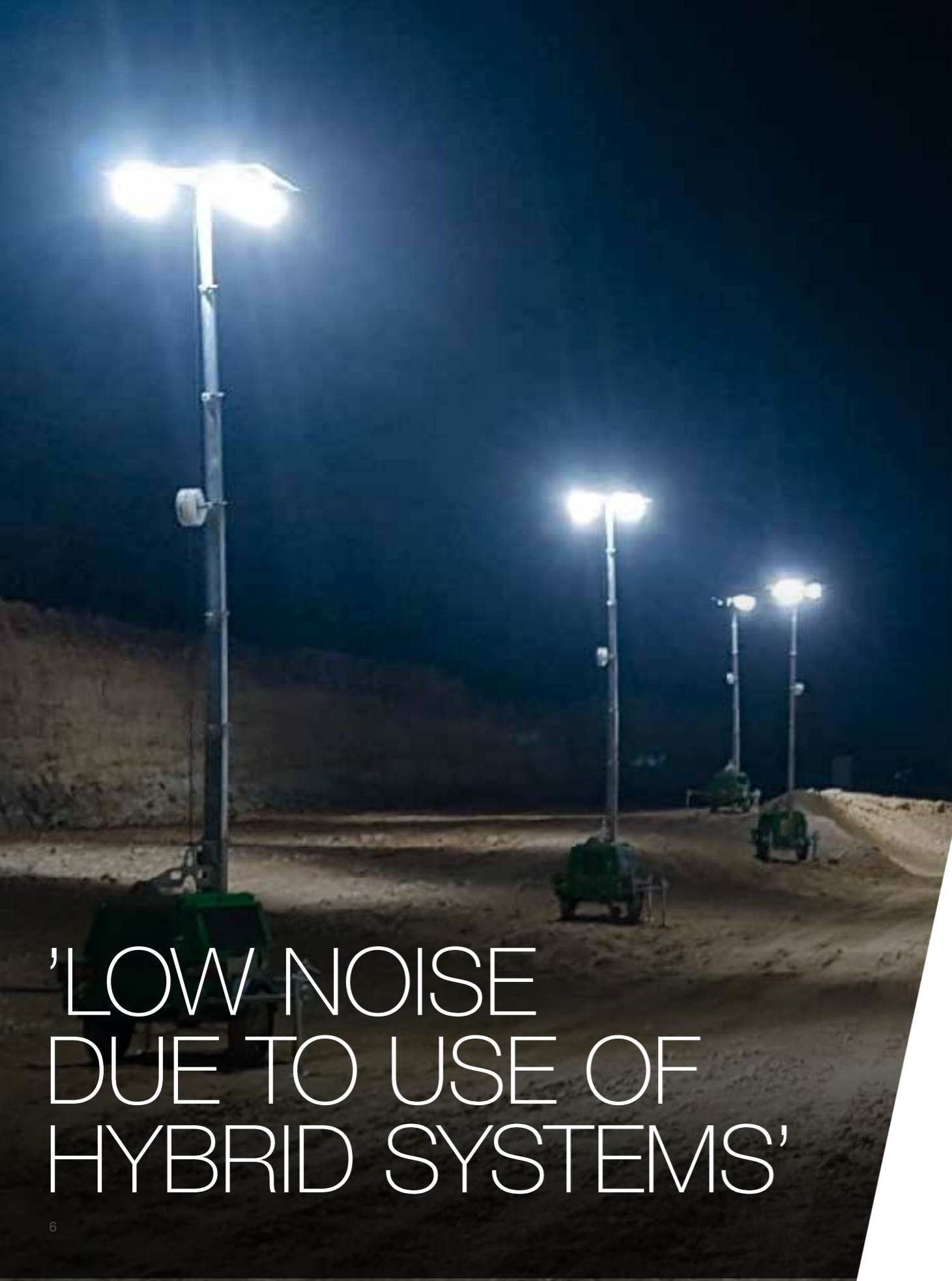

'LOW NOISE  
DUE TO USE OF  
HYBRID SYSTEMS'

# LIGHTING

## HYBRID POWERED



HYBRID LED LIGHT  
TOWER TRAILER (LLTT-H)



HYBRID LED LIGHT TOWER  
BUCKET (LLTB-H)

## SOLAR BATTERY POWERED



LED LIGHT TOWER TRAILER  
(LLTT)



LED LIGHT TOWER UNIT  
(LLTU)



# CRASH



'ONLY EUROPEAN TMA MANUFACTURER THAT PASSED NCHRP 350 & MASH TESTING'

## MASH TESTED

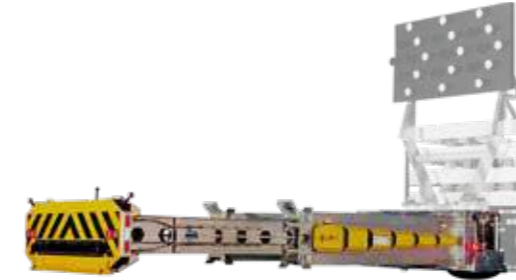

BLADE - TRUCK MOUNTED ATTENUATOR

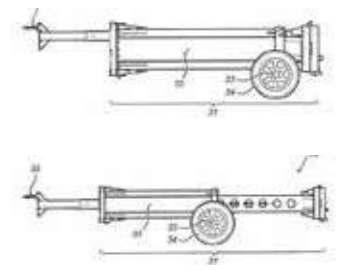

BLADE - TRAILER TRUCK MOUNTED ATTENUATOR

## NCHRP 350 TESTED



LIGHT TRUCK MOUNTED ATTENUATOR (LTMA)



TRAILER TRUCK MOUNTED ATTENUATOR (TTMA)



TRUCK MOUNTED ATTENUATOR-US (TMA-US)

## NCHRP 350 EU TESTED



TRUCK MOUNTED ATTENUATOR-EU (TMA-EU)

## ARROWBOARDS



OPTIONAL ARROW BOARDS FOR TMAs



RED X LIGHT BOARD





'VMS PRODUCTS  
BUILT ACCORDING  
YOUR SPECS'

# TRAFFIC



SOLAR MESSAGE TRAILER  
(SMT)



MOBILE VARIABLE MESSAGE  
SIGNS (VMS)



ARROW TRAILERS  
(AT)



SOLAR MESSAGE  
UNIT (SMU)



MOBILE LANE SIGNALING  
SYSTEM (MLS)



RIS SYSTEM  
(RIS)



RUMBLE MAT LAYER  
(RML)



AUTO CONE  
(A.C.)



PICK & PLACE TMA ARROW  
WARNING UNIT (P.P.T.)

# LIGHTING

SOLAR AND HYBRID  
POWERED LIGHT  
TOWERS. SAVE ON  
DAILY OPERATIONAL  
COSTS BY LOWERING  
REFUELING AND  
MAINTENANCE

A NEW CONCEPT FOR THE WORLD  
WIDE MARKET...

HYBRID POWERED



**HYBRID LED LIGHT TOWER TRAILER**  
(LLTT-H) HYBRID POWERED



**HYBRID LED LIGHT TOWER BUCKET**  
(LLTB-H) HYBRID POWERED

SOLAR BATTERY POWERED



**LED LIGHT TOWER TRAILER**  
(LLTT) SOLAR POWERED



**LED LIGHT TOWER UNIT**  
(LLTU) SOLAR POWERED



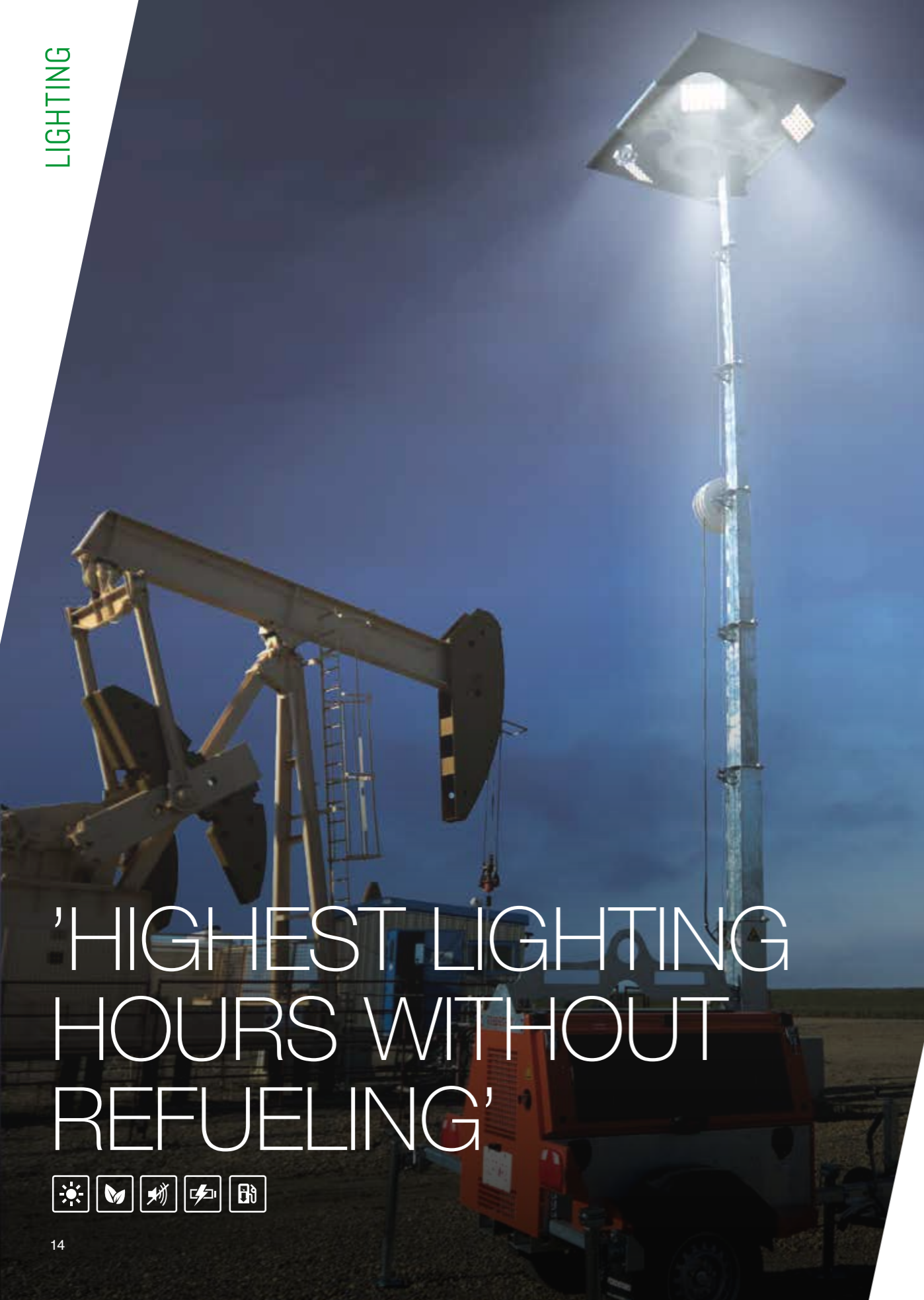

'HIGHEST LIGHTING HOURS WITHOUT REFUELING'



# HYBRID LED LIGHT TOWER

(SMART SOLAR- BATTERY- AND DIESEL POWER SYSTEM)



**SOLAR POWER SYSTEM (350 W)**

HIGH-EFFICIENCY LED FLOOD LIGHTS ALSO EXPLOSION PROOF LIGHTS AVAILABLE

PHOTOCELL DAYLIGHT SENSOR (AUTOMATIC ON/OFF)

SPRING- DRIVEN CABLE DRUM

GEO FENCING

7 SECTION VERTICAL TOWER (STEEL GALVANISED)

FORKLIFT SPROCKETS ON TOP + BELOW CHASSIS

INFORMATION LED BACKLIGHT CONTROLLER SCREEN

**SOLAR POWER SYSTEM (350 W)**

HYBRID DIESEL GENERATOR

FUEL TANK CAPACITY 140 L

DRIP TRAY

TWO FRONT + TWO BACK OUTRIGGERS AND LEVELING JACKS

TORSION RUBBER SUSPENSION AXLE

**FUEL CONSUMPTION 2.5L EACH DAY/**

60 NIGHTS BEFORE REFUELING!

\* ASK FOR FULL SPECIFICATIONS





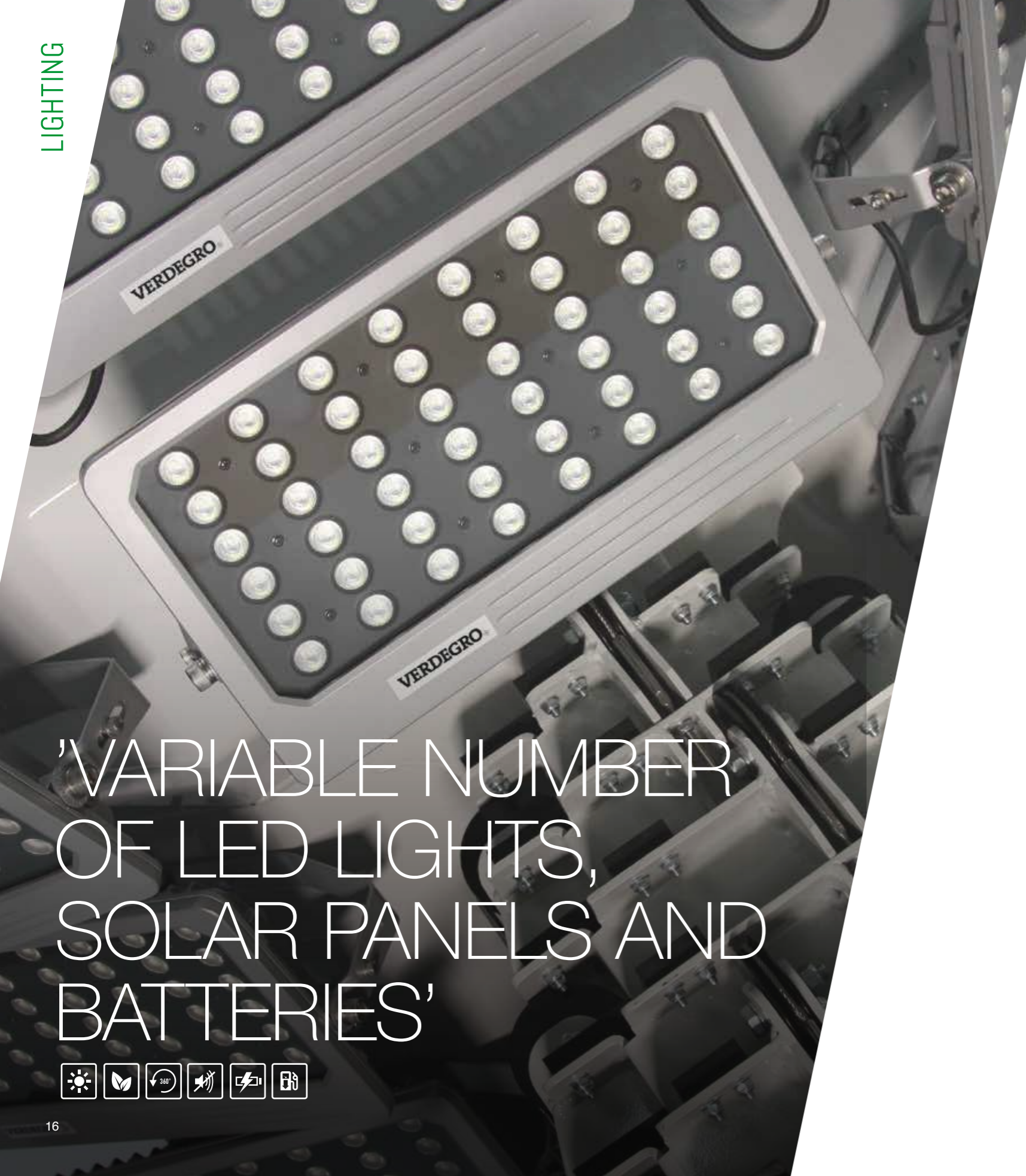

'VARIABLE NUMBER OF LED LIGHTS, SOLAR PANELS AND BATTERIES'



## HYBRID LED LIGHT TOWER BUCKET

(SMART SOLAR- BATTERY- AND DIESEL POWER SYSTEM)

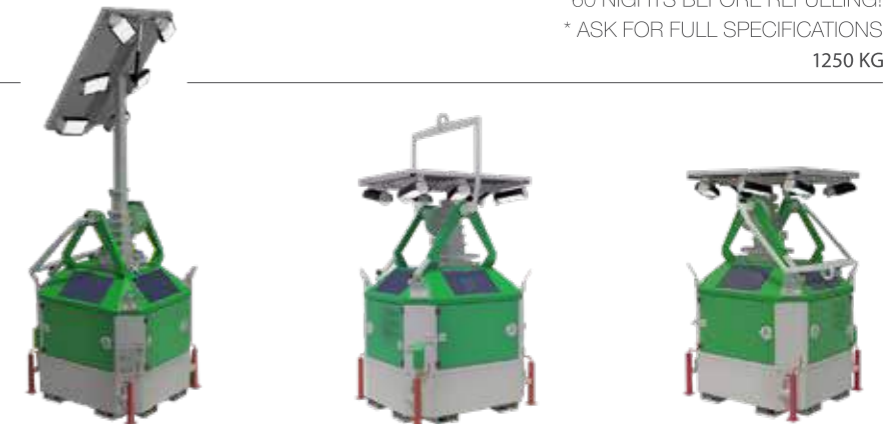
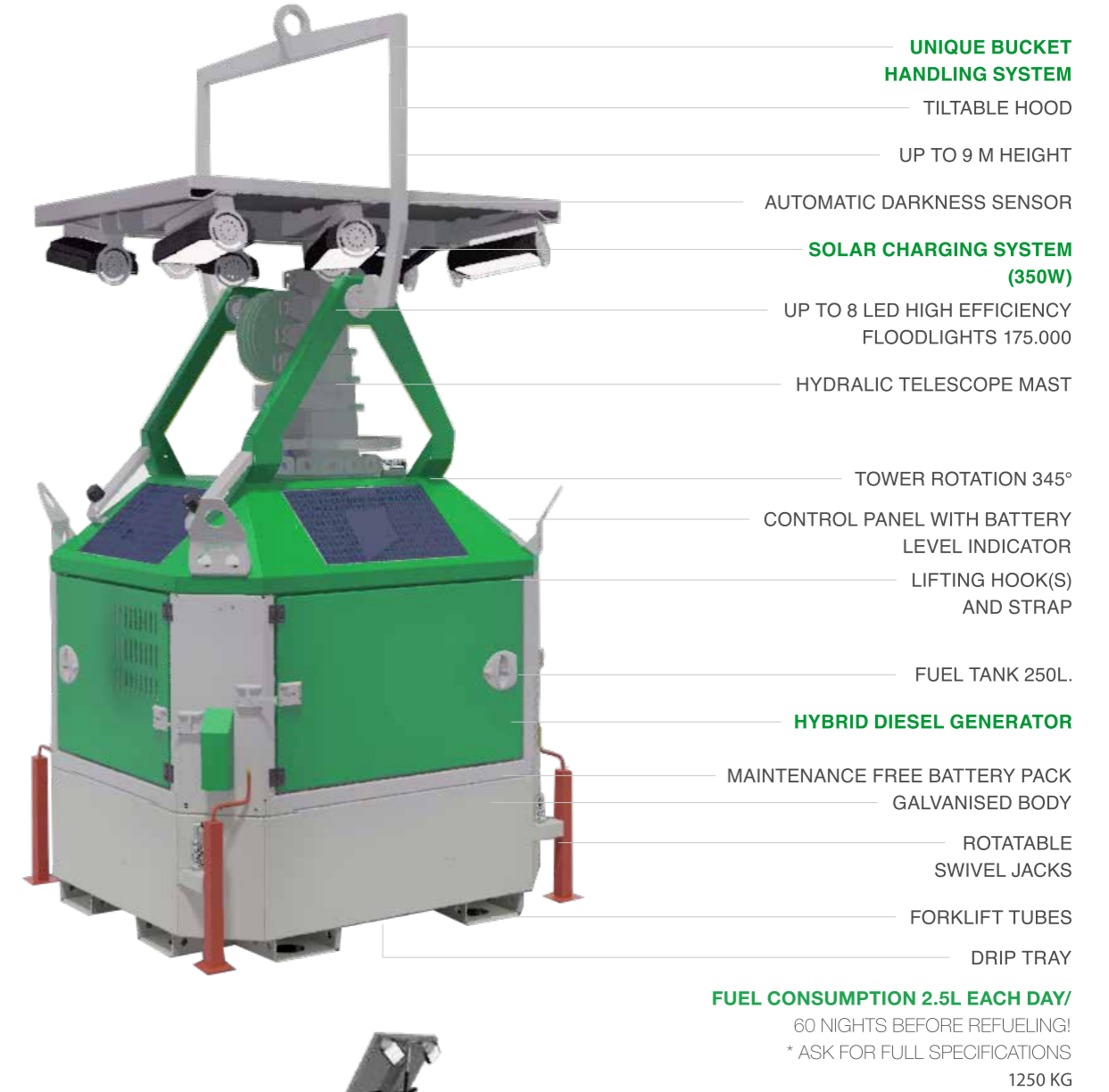



# 'SOLAR POWERED CO2 NEUTRAL AND NOISELESS MOBILE LIGHTING TRAILER'



## LED LIGHT TOWER TRAILER

(FULL BATTERY LED LIGHT TOWER WITH SOLAR SYSTEM)

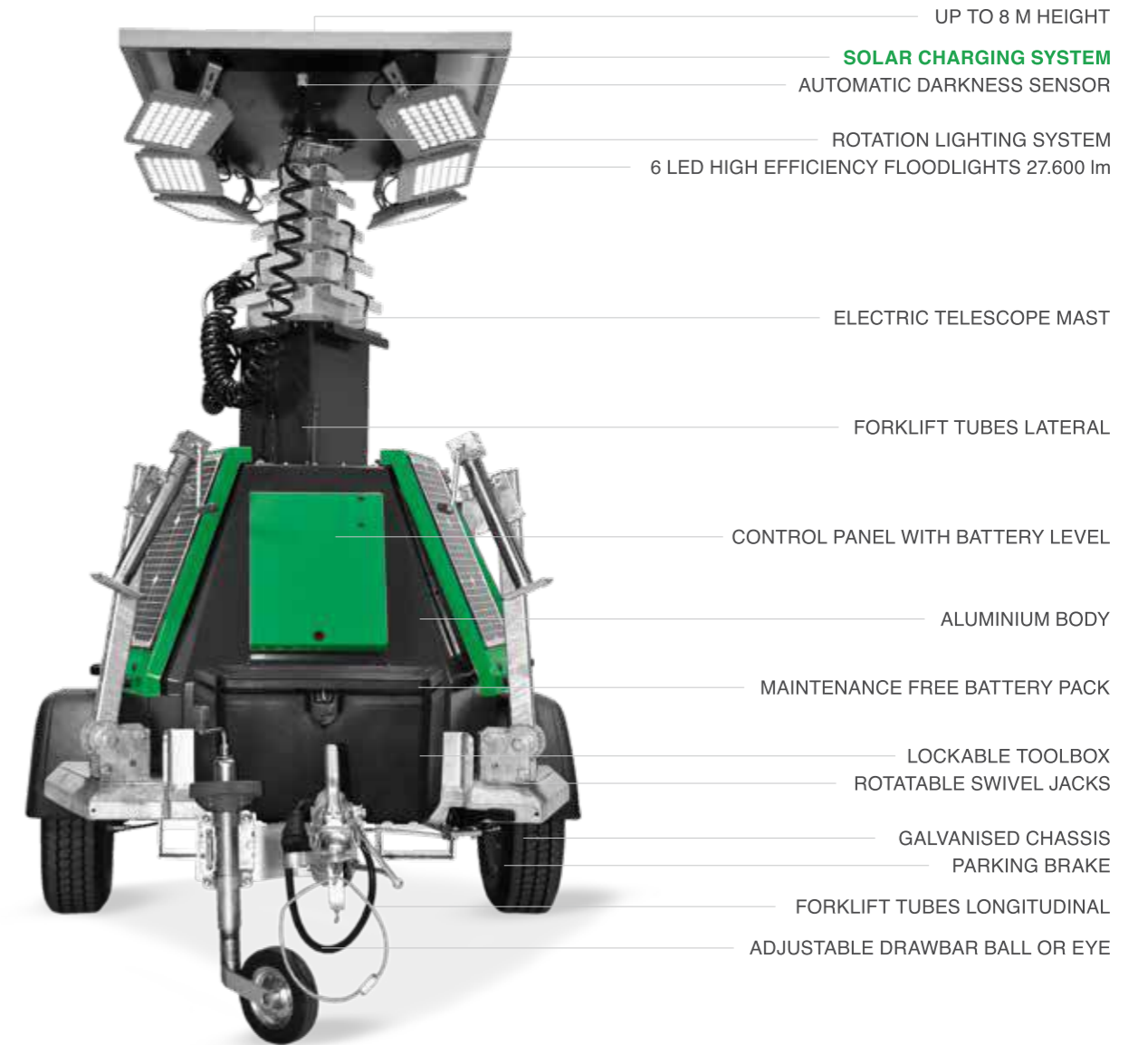

745 KG







'UP TO 30 LED LIGHT TOWER UNITS IN ONE TRANSPORT'



## LED LIGHT TOWER UNIT

(FULL BATTERY LED LIGHT TOWER WITH SOLAR SYSTEM)







ALL UNIQUE &  
FULL SCALE CRASH  
TESTED SYSTEMS'

VISIT [WWW.VERDEGRO.COM/PRODUCTS/CRASH](http://WWW.VERDEGRO.COM/PRODUCTS/CRASH)





# CRASH

TRAFFIC AND  
WORKZONE SAFETY:  
USE OF ALUMINUM  
AND GALVANISED  
STEEL PARTS ONLY

A NEW CONCEPT FOR THE WORLD  
WIDE MARKET...

MASH TESTED

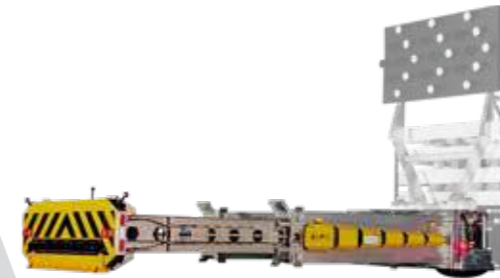

**BLADE - TRUCK MOUNTED  
ATTENUATOR**

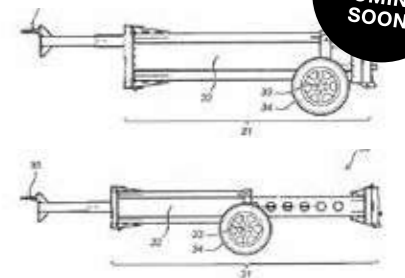

**BLADE - TRAILER TRUCK  
MOUNTED ATTENUATOR**

TRAILER  
COMING  
SOON

NCHRP 350 TESTED



**LIGHT TRUCK MOUNTED  
ATTENUATOR (LTMA)**

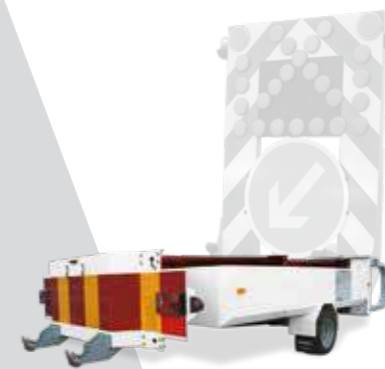

**TRAILER TRUCK MOUNTED  
ATTENUATOR (TTMA)**



**TRUCK MOUNTED  
ATTENUATOR-US (TMA-US)**

NCHRP 350 EU TESTED



**TRUCK MOUNTED  
ATTENUATOR-EU (TMA-EU)**

ARROWBOARDS



**OPTIONAL ARROW  
BOARDS FOR TMA'S**



**RED X LIGHT BOARD**



**NEW!** PROUDLY TESTED IN THE U.S.A.

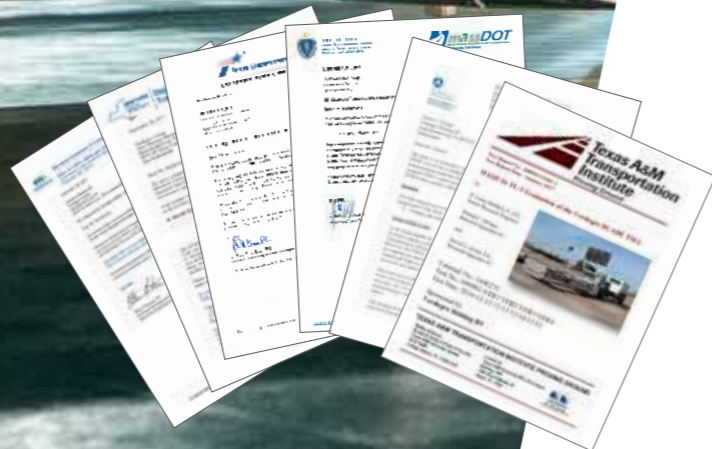

# BLADE - TRUCK MOUNTED ATTENUATOR

**MORE INFORMATION ABOUT THE BLADE SEE P68.**  
CONFIGURATE BLADE ACCORDING YOUR SPECS  
[www.blade-tma.com/configurator](http://www.blade-tma.com/configurator)

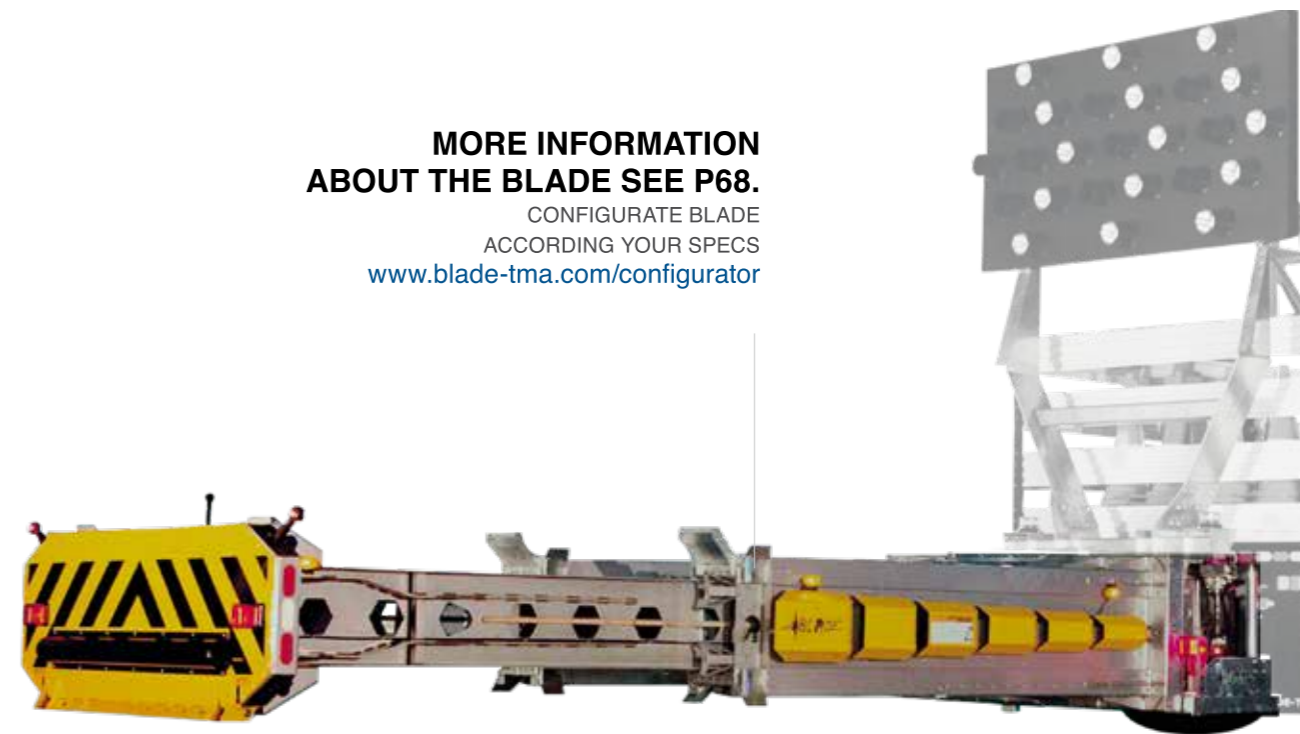

# BLADE - TRAILER TRUCK MOUNTED ATTENUATOR

COMING SOON

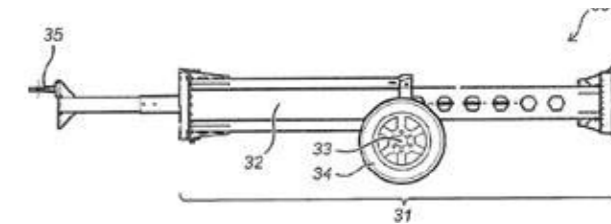
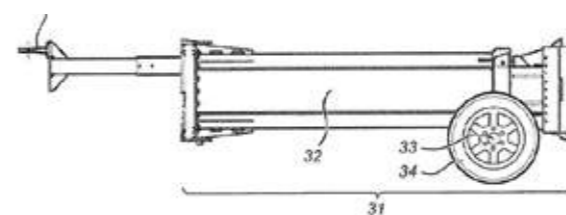



# LIGHT TRUCK MOUNTED ATTENUATOR

LTMA (70K)

ARROW BOARDS  
FOR LTMA'S  
SEE P38!

TESTED ACCORDING THE NCHRP-350  
TL-2 70 KPH (2-50 / 2-51).  
2000P TESTS DONE WITH  
2000 KG US PICK-UP TRUCK

PERSONALIZED WITH TWO TONE PAINT JOB

2.5 TON VAN UP TO 9 TON TRUCK

HYDRAULIC ROTATING  
SYSTEM INCLUDED

OPTIONAL SUBFRAME FOR  
MOUNTING BETWEEN CHASSIS  
AND CARGOFLOOR ON

ENERGY ABSORPTION  
ALUMINUM MOISTURE  
PROOF CARTRIDGE

ENERGY ABSORPTION  
REPLACEABLE ALUMINUM TUBES

FIRST IMPACT ALUMINUM REPLACEABLE HOOD

REFLECTIVE FOIL ACCORDING YOUR SPECS

280 KG



# FOR LIGHT VEHICLES TESTED AND APPROVED



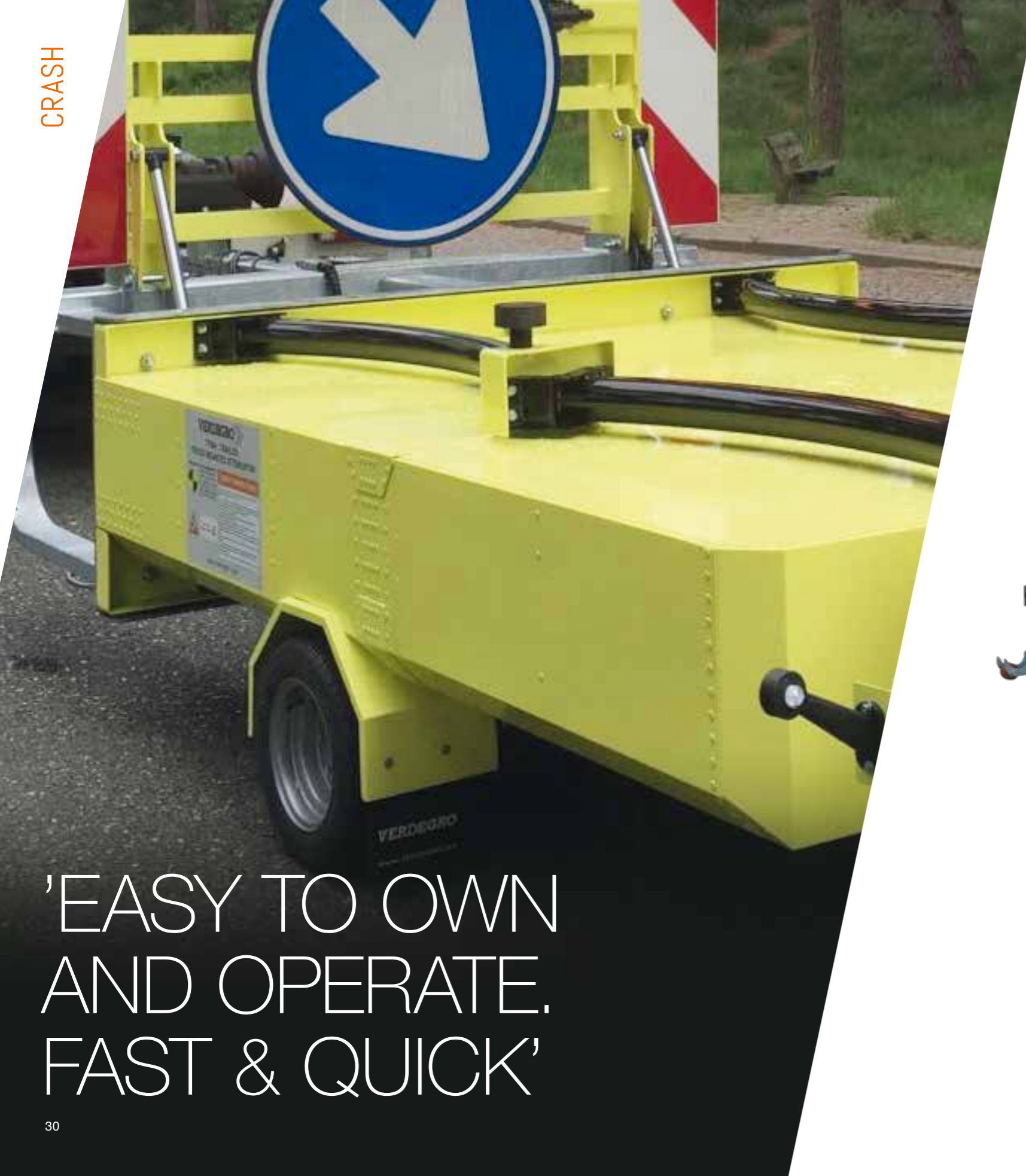

'EASY TO OWN AND OPERATE. FAST & QUICK'



# TRAILER TRUCK MOUNTED ATTENUATOR

TTMA (100K)

ARROW BOARDS FOR TTMA'S SEE P38!

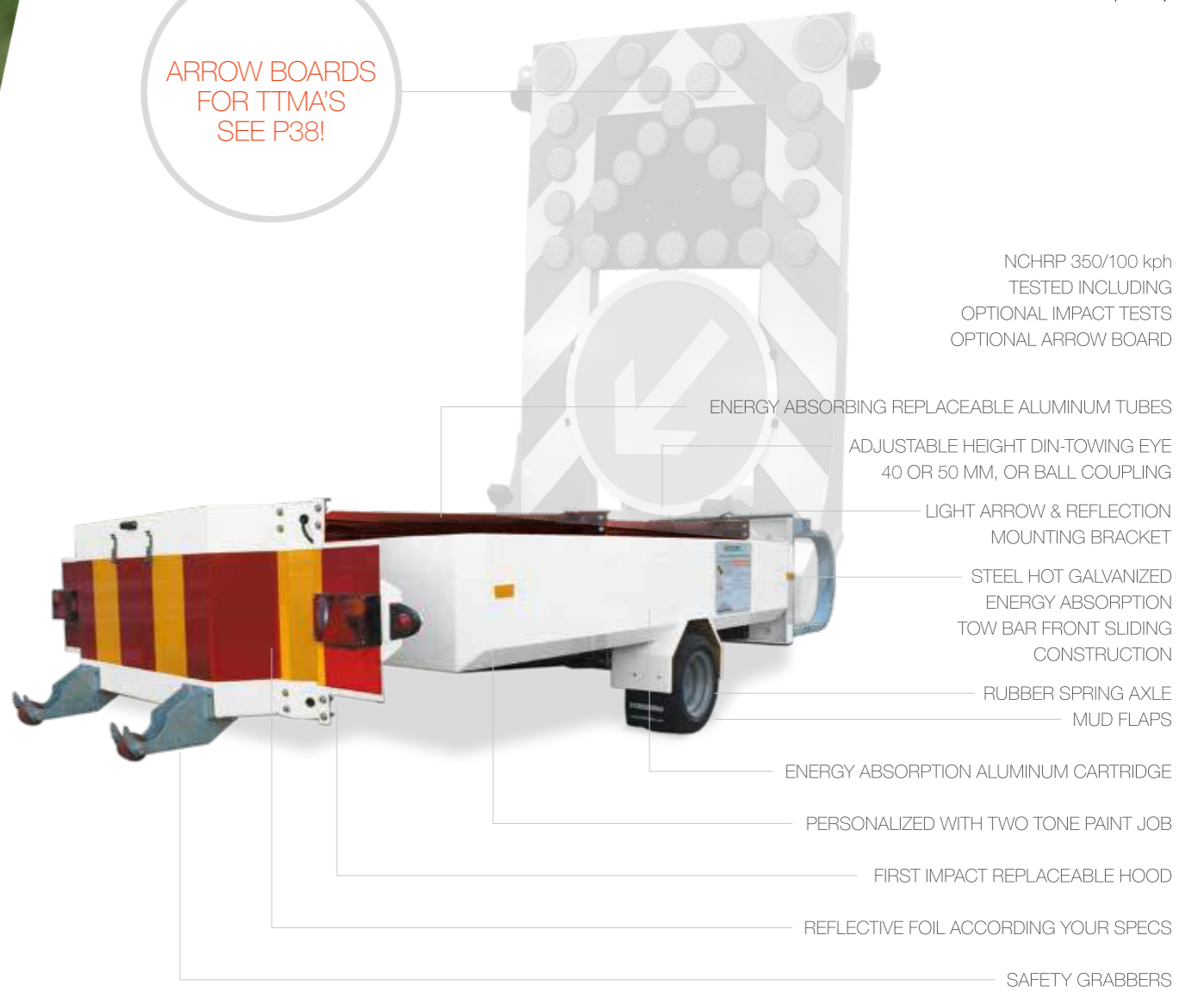

NCHRP 350/100 kph TESTED INCLUDING OPTIONAL IMPACT TESTS OPTIONAL ARROW BOARD

740 KG







# TRUCK MOUNTED ATTENUATOR-US

TMA-US (100K)

ARROW BOARDS FOR TMA'S SEE P38!

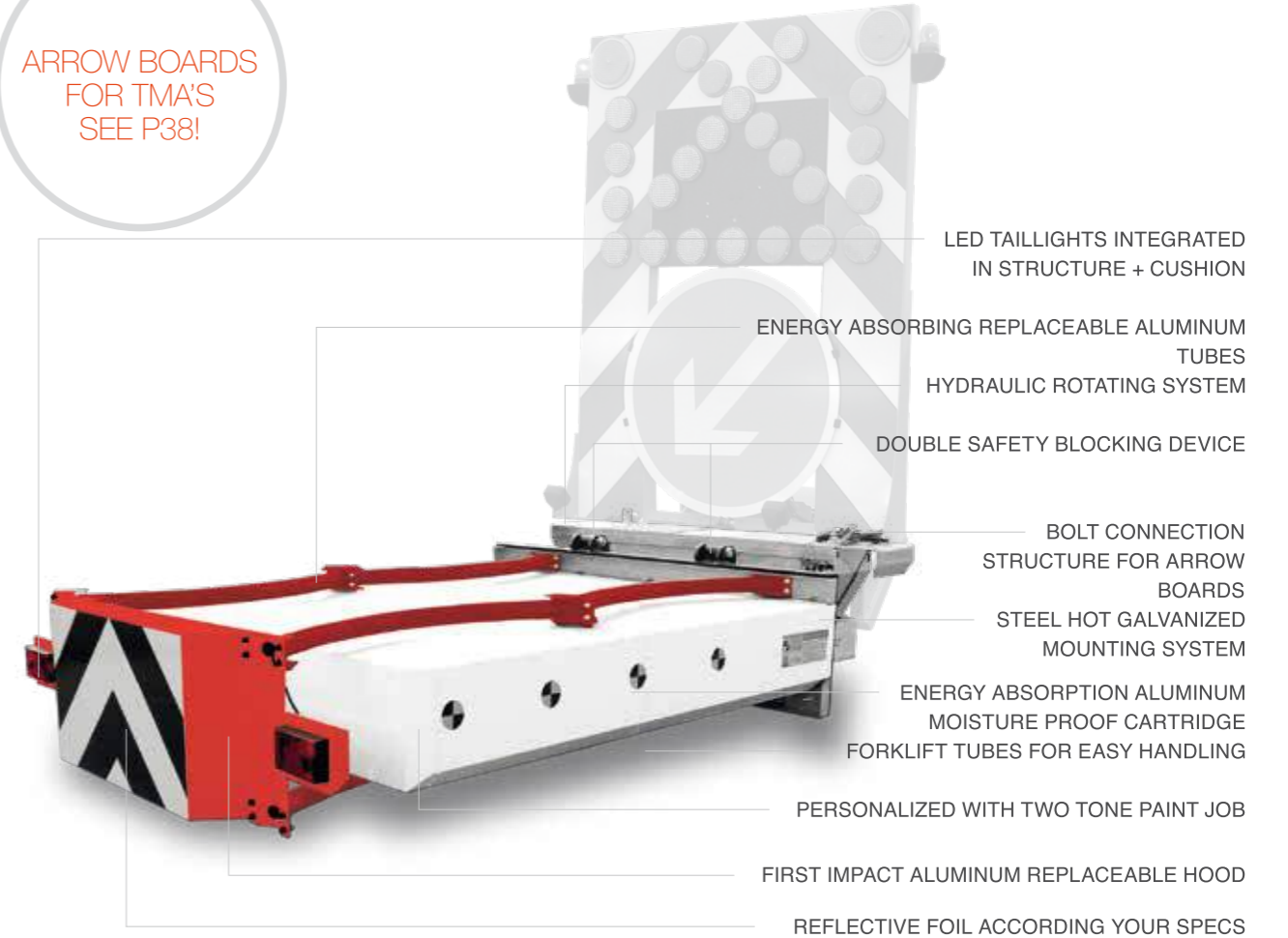

TESTED ACCORDING THE NCHRP 350. TL-3 100 KPH (3-50 / 3-51 / 3-52 / 3-53).  
 2000P TESTS WERE DONE WITH A 2000 KG US PICK-UP TRUCK  
 TESTED ACCORDING THE OPTIONAL UK 110 KPH TEST (TD 49/07).

950 KG

'A UNIQUE DESIGN  
 PROVEN QUALITY'





# TRUCK MOUNTED ATTENUATOR-EU

TMA-EU (100K)



ARROW BOARDS FOR TMA'S SEE P38!



TESTED IN THE SPIRIT OF THE NCHRP 350 TL-3 100 KPH (3-50/3-51/3-52/3-53) 2000P TEST'S WERE DONE WITH 2000KG EUROPEAN STYLE SUV'S



750 KG

# 'EUROPEAN STANDARDS, PROVEN QUALITY'

WE ONLY USE HIGH QUALITY ALUMINUM INSIDE **INSTEAD OF NONDURABLE PAPER!**







'FUTURE PROOF  
TRAFFIC MANAGMENT  
EQUIPMENT.'

# RED X LIGHT BOARD



- 13X RED 200 MM LED LIGHTS ACC/ BS EN 12352:2006, CLASS L8H
- 9 RED LIGHTS FORM THE CROSS AS A STEADY LIGHT WITH ORTHAGONAL ARMS
- THE 4 LAMPS OUTSIDE THE RED CROSS FLASH VERTICALLY IN PAIRS AT A RATE OF NOT LESS THEN 60 AND NOT MORE THAN 90 FLASHES PER MINUTE
- FOLDED PANEL YELLOW BACKING BOARD 610, EITHER BS EN 1899 CLASS 2
- AUTOMATIC CABIN CONTROLLED ROTATING REFLECTIVE SIGN (LEFT- &RIGHT- & HARD SHOULDER & CONVOY SIGNS)
- FOLDED YELLOW BACKING BOARD EITHER BS EN 1899 CLASS 2
- DIAGRAM P7029 "CONVOY VEHICLE NO OVERTAKING"
- RED X ARROW BOARD CAN BE TRUCK BED OR TMA MOUNTED (BRAND VERDEGRO)

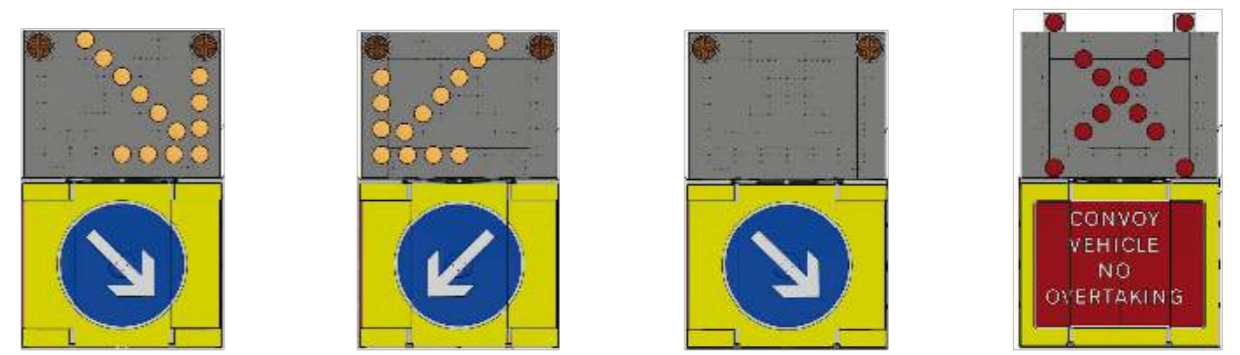





ARROW  
BOARDS  
FOR TMA

'ARROW BOARDS  
TO FIT YOUR  
SPECIFIC NEEDS'

# OPTIONAL ARROW BOARD?

CONTACT US AND MAKE  
YOUR TMA COMPLETE  
[SALES@VERDEGRO.COM](mailto:SALES@VERDEGRO.COM)







'A WIDE RANGE  
OF HIGH QUALITY  
TRAFFIC SYSTEMS'

VISIT [WWW.VERDEGRO.COM/PRODUCTS/TRAFFIC](http://WWW.VERDEGRO.COM/PRODUCTS/TRAFFIC)

# TRAFFIC

THE INTERNATIONAL  
VMS STANDARDS  
STARTS HERE

A NEW CONCEPT FOR  
THE WORLD WIDE MARKET...



SOLAR MESSAGE TRAILER  
(S.M.T.)



MOBILE VARIABLE  
MESSAGE SIGNS (V.M.S.)



ARROW TRAILERS  
(A.T.)



SOLAR MESSAGE  
UNIT (S.M.U.)



MOBILE LANE  
SIGNALING (M.L.S.)



RIS SYSTEM  
(R.I.S.)



RUMBLE MAT LAYER  
(R.M.L.)



AUTO CONE  
(A.C.)



PICK & PLACE TMA ARROW  
WARNING UNIT (P.P.T.)



# SOLAR MESSAGE TRAILER

OPTICS ACC. NEN-EN 12966  
 EMC TESTED (ELECTROMAGNETIC COMPATIBILITY)  
 WIFI OR UMTS WIRELESS COMMUNICATION



750 KG (UP TO 1100 KG)



'FULL COLOR  
 SOLAR POWERED  
 MESSAGE TRAILER'





# 'MOBILE VARIABLE MESSAGE SIGNS'



## MOBILE VARIABLE MESSAGE SIGNS



- SOLAR POWERED
- SIGN PROGRAMMABLE BY TABLET OR SMARTPHONE
- WIFI AND 3G UMTS WIRELESS COMMUNICATION
- FULL COLOR VMS ACC. YOUR SPECIFICATIONS
- TRAILER CHASSIS OPEN OR CLOSED DESIGN
- OPTIONAL HYBRID SYSTEM OR DIESEL GENERATOR
- HYDRAULIC LEVELING SYSTEM, OPTIONAL VMS ROTATION
- SMALL OR WIDE TRAILER CHASSIS
- DOUBLE OR SINGLE AXLE TRAILER

OPTICS ACC. NEN-EN 12966  
 EMC TESTED (ELECTROMAGNETIC COMPATIBILITY)  
 WIFI OR UMTS WIRELESS COMMUNICATION

750 KG (UP TO 1400 KG)







# 'ARROW TRAILERS AND WARNING TRAILERS'



## ARROW TRAILERS

SOLAR POWERED



LED WARNING LIGHTS ACC YOUR SPECIFICATION

CLOSED OR OPEN TRAILER

REFLECTIVE FOIL ACC YOUR SPECIFICATIONS

HYDRAULIC OR MANUAL SYSTEM

SMALL OR WIDE CHASSIS

SINGLE OR DOUBLE AXLE

VERDEGRO MUD FLAPS

750 KG (UP TO 1400 KG)





# 'TEMPORARY STAND ALONE SOLAR OR HYBRID POWERED ROAD INFORMATION PANEL'



## SOLAR MESSAGE UNIT

PATENT NO 2001420 (SMU)



SOLAR CHARGING SYSTEM  
UP TO 6,5 M HEIGHT

LOW POWER CONSUMPTION FULL COLOR  
LED DISPLAY

SIGN PROGRAMMABLE BY TABLET OR SMARTPHONE

HYDRAULIC LIFT SYSTEM

MAINTENANCE FREE BATTERY PACK

HYBRID POWER SYSTEM

PERSONALIZED WITH TWO TONE PAINT JOB

GALVANISED STEEL CONSTRUCTION FRAME  
FORKLIFT TUBES

OPTICS ACC. NEN-EN 12966  
EMC TESTED (ELECTROMAGNETIC COMPATIBILITY)  
WIFI OR UMTS WIRELESS COMMUNICATION

1500 KG







'DIFFERENT MOBILE  
LANE SIGNALING  
SYSTEMS AVAILABLE'

# MOBILE LANE SIGNALING

(MLS)

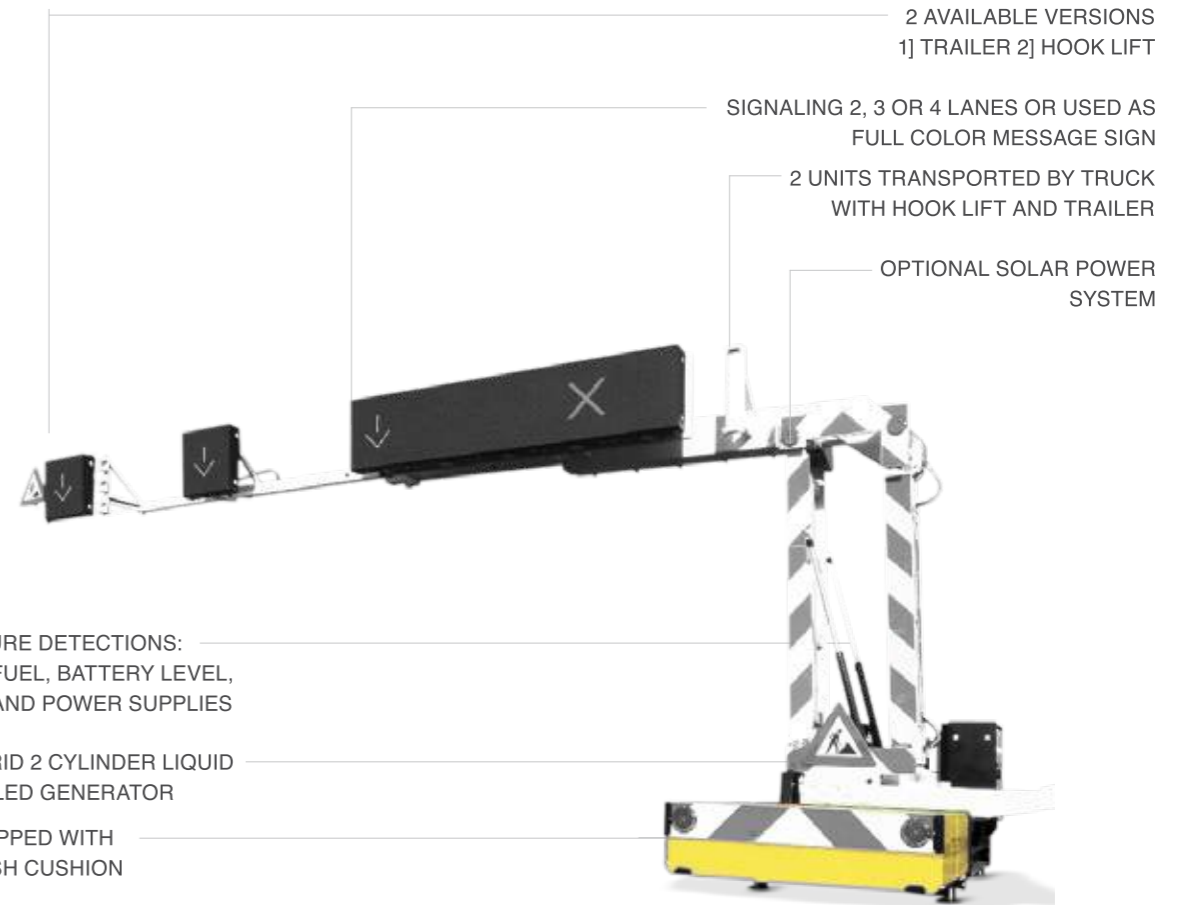

OPTICS ACC. NEN-EN 12966  
EMC TESTED (ELECTROMAGNETIC COMPATIBILITY)  
3G/ WIFI OR UMTS WIRELESS COMMUNICATION

± 14.000 KG







'DIFFERENT  
MOBILE LANE  
SIGNALING SYSTEMS  
AVAILABLE'

CE  
**RIS SYSTEM**



FAILURE DETECTIONS:  
OIL, FUEL, BATTERY LEVEL,  
LED AND POWER SUPPLIES

HYBRID 2 CYLINDER LIQUID  
COOLED GENERATOR

OPTIONAL EQUIPPED  
WITH CRASH CUSHION

OPTICS ACC. NEN-EN 12966  
EMC TESTED (ELECTROMAGNETIC COMPATIBILITY)  
WIFI OR UMTS WIRELESS COMMUNICATION

± 10.000 KG







'UNIQUE DESIGN  
OPERATIONAL FROM  
TRUCK CABIN'



## RUMBLE MAT LAYER

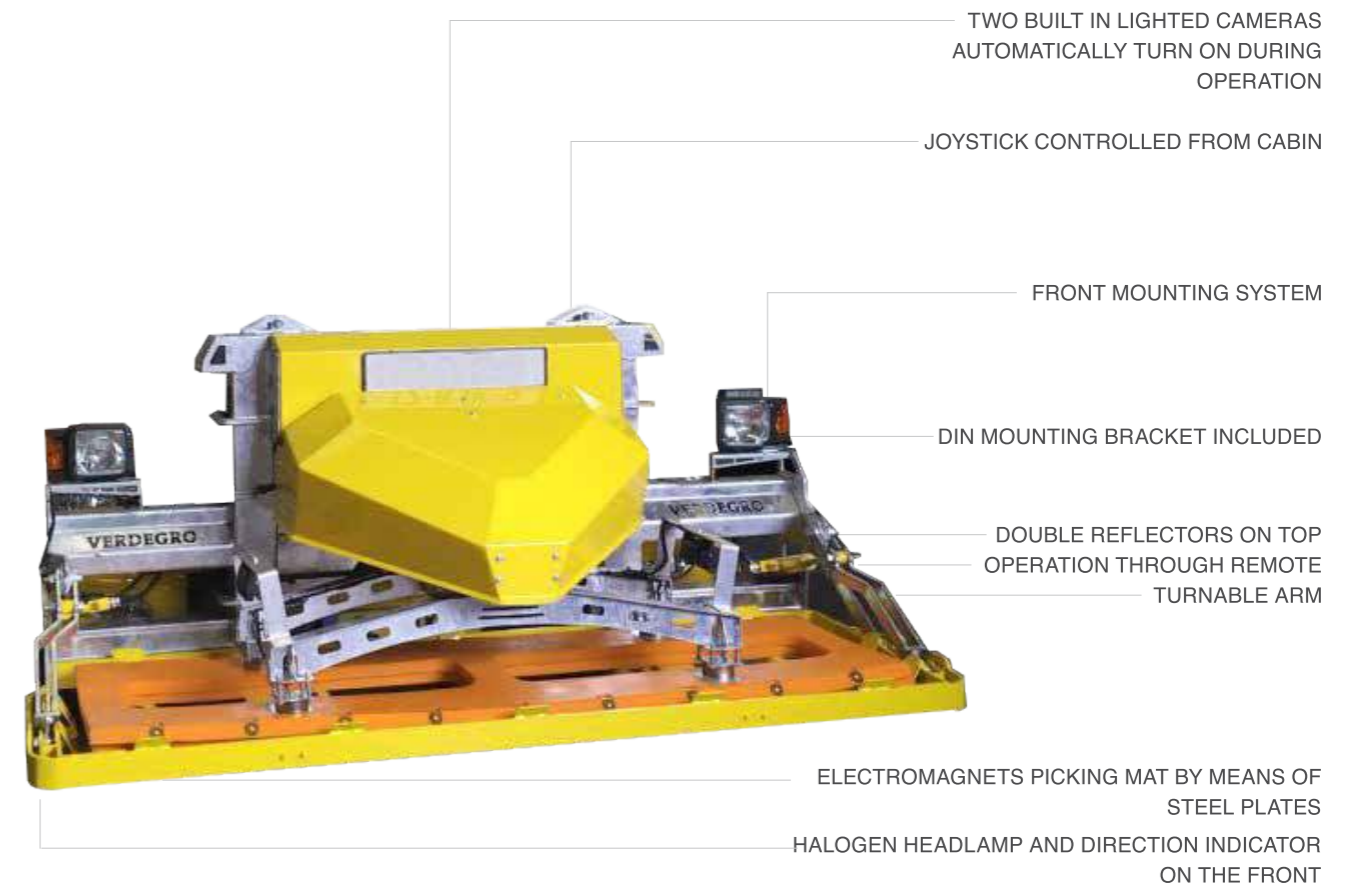

R.M.L.

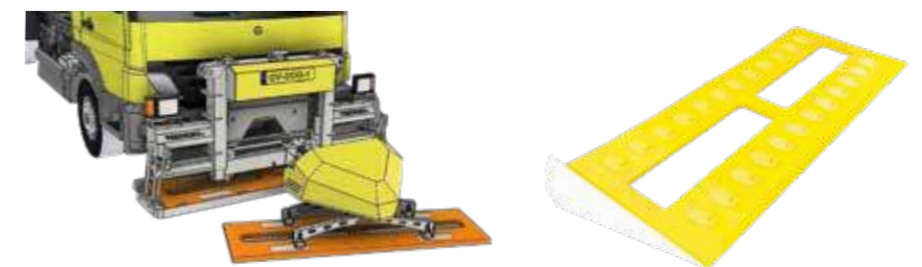





'PICK & PLACE CONES FULL AUTOMATIC'



# AUTO CONE



AUTO CONE SUGGESTED TO BE INSTALLED ON 4 X 2 VEHICLE CHASSIS ( MAN / VOLVO / MERCEDES / DAF / OTHERS ON REQUEST)

A.C.





# PICK & PLACE TMA ARROW WARNING UNIT



# 'PICK AND PLACE TMA'

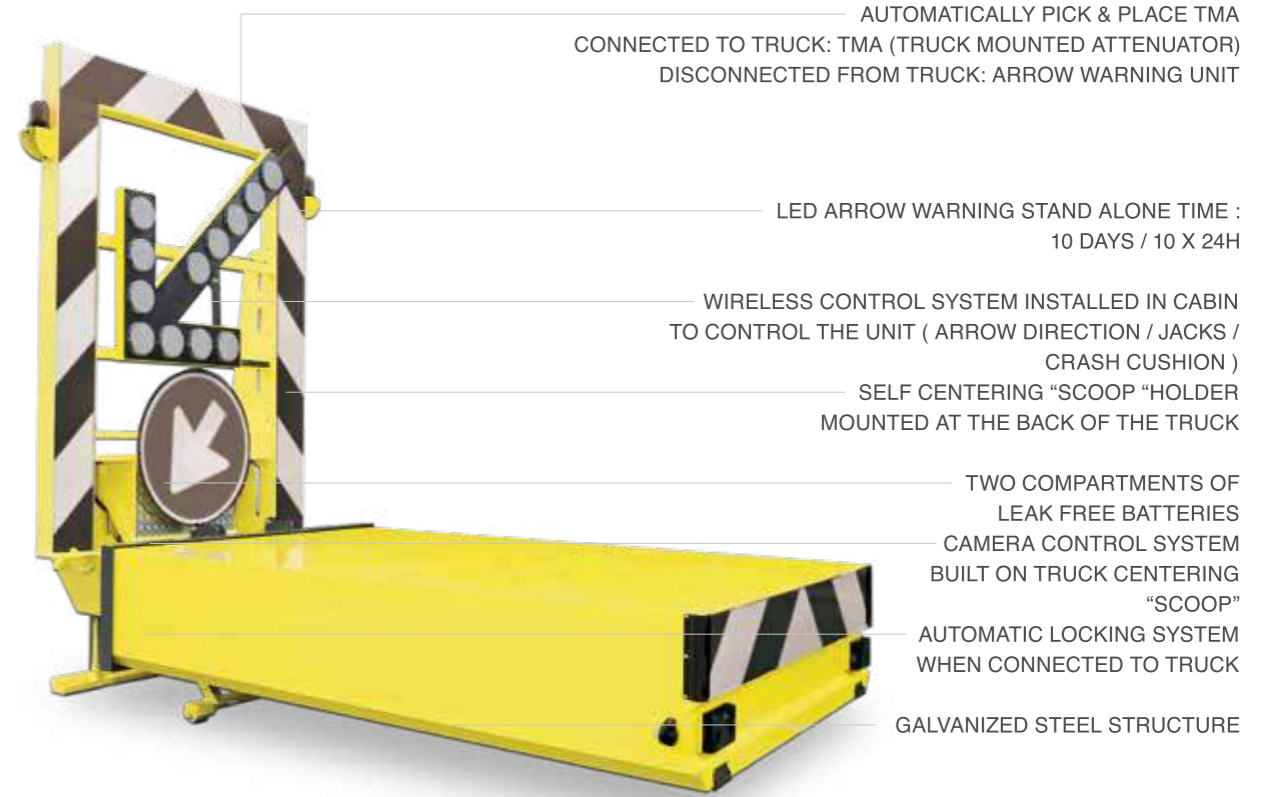





'ENABLES LANE CLOSURES WITHOUT ACTUALLY HAVING PEOPLE OUT ON THE LANE'



# CUSTOMIZE YOUR PRODUCT TO YOUR COMPANY COLORS



RAL1023



RAL1003



RAL3020



RAL5005

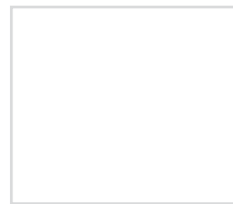

RAL9003

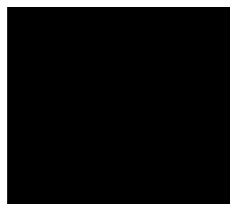

RAL9005



RAL9006



RAL6037



ALL OUR PRODUCTS ARE AVAILABLE  
IN EVERY RAL COLOR

**'IT'S ALL ABOUT SAVING LIVES'**

'PROVEN SAFETY ALSO WHEN IT'S  
NOT A TEST.'



# VERDEGRO®

## GET YOUR GOODIES & JOIN US!



UPLOAD YOUR PRODUCT PHOTO AND GET VERDEGRO GOODIES!

[WWW.VERDEGRO.COM](http://WWW.VERDEGRO.COM)



SWEATER VERDEGRO

CAP VERDEGRO BLACK



BAG VERDEGRO



CAP CAMOUFLAGE



CAP BLADE WINTER A



CAP BLADE WINTER B

UPLOAD YOUR BLADE PHOTO AND GET BLADE GOODIES!

[WWW.BLADE-TMA.COM](http://WWW.BLADE-TMA.COM)



SWEATER BLADE



CAP BLADE GREY

QUESTIONS ABOUT OUR GOODIES?

MAIL: [SALES@VERDEGRO.COM](mailto:SALES@VERDEGRO.COM)

[WWW.VERDEGRO.COM](http://WWW.VERDEGRO.COM)

[WWW.BLADE-TMA.COM](http://WWW.BLADE-TMA.COM)





# PROUDLY TESTED IN THE U.S.A.

THE No.1 MASH TMA; FINALLY A NEW LEADER  
IS BORN. BLADE, THE LONG AWAITED NEW  
TRUCK MOUNTED ATTENUATOR.

## THIS IS BLADE

The No1 MASH TMA; Finally a new leader is born. BLADE, the long awaited new Truck Mounted Attenuator. Full scale crash tested according the Manual for Assessing Safety Hardware (MASH) that supersedes the 20 year old NCHRP-350.

## WHY MASH?

The safety changes are mainly necessitated by alterations made to vehicles over the past decade. Cars have greatly increased in size, so different safety regulations are required to keep the occupants safe. The average bumper height on light trucks has risen considerably since 1993, so previous highway safety designs are no longer adequate

## WHAT'S THE DIFFERENCE FOR TMA'S

The new MASH 2016 standard sets stricter criteria for Truck Mounted Attenuator's, bigger, heavier and newer test vehicles has to be used during testing, also the shadow vehicle criteria are stricter and much heavier, upper and lower truck weight has to be tested, ballast has to be fixed and also the arrow board together with the TMA construction must have been tested. The optional offset- and offset angle tests are now required in MASH!

THE FIRST TO PASS ALL 4  
MANDATORY MASH TESTS WITH 4  
IDENTICAL TMA'S RANDOM PICKED  
IN JUST ONE WEEK.



THE FIRST IN THE WORLD  
WITH TEST RESULTS WITHIN  
THE PREFERRED MASH  
VALUES

PERSONALIZE YOUR  
OWN BLADE ONLINE  
[WWW.BLADE-TMA.COM](http://WWW.BLADE-TMA.COM)

**TABLE OF CONTENTS AND DIMENSIONS**

Transport height	12ft.11in	Width:	7ft. 6.7in
Installation length, excl. bracket:	19ft.4in	Level system:	+/- 4 degrees



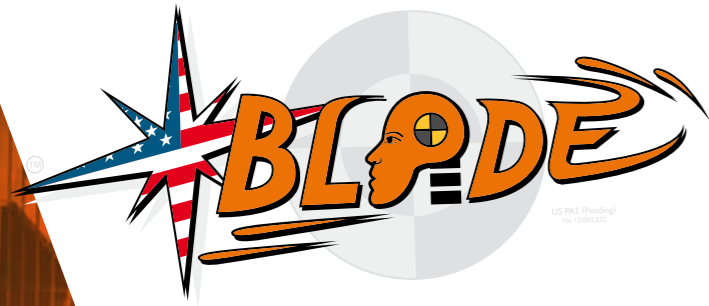

# CHOOSE YOUR ACCESSORIES

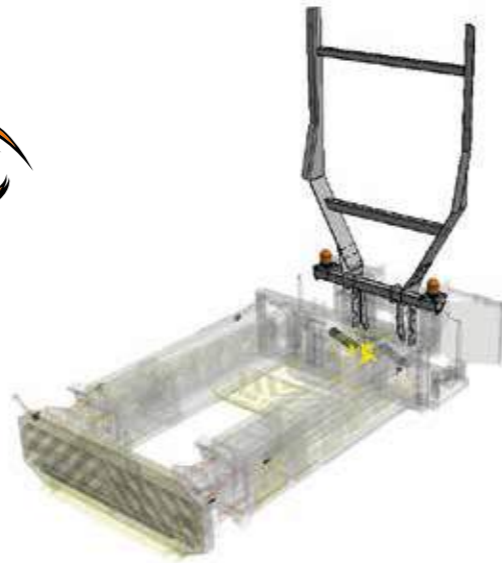

- 1** **ARROW BOARD BRACKET**  
 FULL SCALE CRASH TESTED
- MODULAR
  - GALVANIZED
  - STANDARD FOR SEVERAL TYPES OF VMS AND ARROW BOARDS
  - LED BEACONS NOT INCLUDED



- 3** **FOIL**
- A BLACK 100MM STRIPING ON THE HOOD
  - 100MM STRIPING AND "CAUTION KEEP CLEAR" ON THE MIDDLE FOIL PLATE
  - OTHER FOILS ON REQUEST

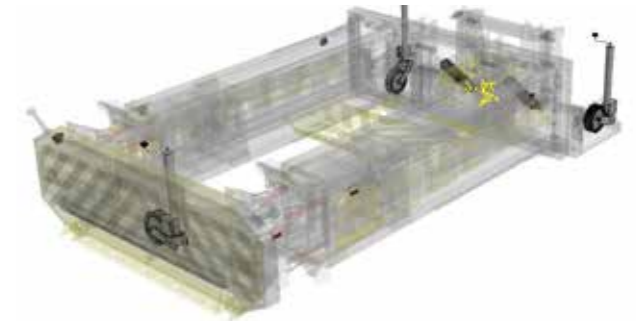

- 4** **JOCKEY WHEELS**
- 3 PIECES OF GALVANIZED JOCKEY WHEELS
  - ONE IS MOUNTED TO THE REAR HOOD, AND 2 PIECES ARE MOUNTED ON THE STEEL GALVANIZED STRUCTURE. ALL FULL-SCALE CRASH TESTED

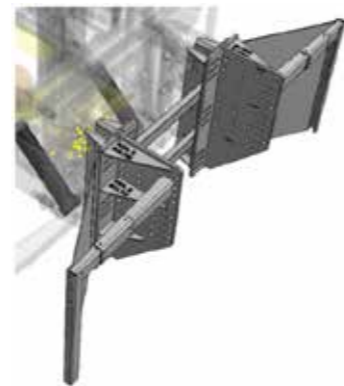

- 2** **TRUCK BRACKET**
- FULL SCALE CRASH TESTED BRACKET
  - GALVANIZED
  - INCLUDING FENDERS (BENDS AWAY THE CUTTED ALU PARTS DURING IMPACT)
  - INCLUDING 6 PIECES HITCHPINS
  - ALL BOLTS AND MATERIALS INCLUDED
  - EASY TO INSTALL! NO WELDING NEEDED
  - ANYONE CAN INSTALL A TMA IN A COUPLE OF HOURS



- 5** **TRUCK BODY**
- SEVERAL DIMENSIONS AVAILABLE
  - WITH OR WITHOUT MAN BUCKET

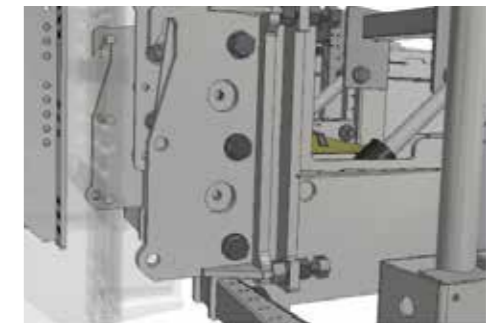

- QUICK CONNECT + LEVEL SYSTEM**
- STANDARD INCLUDED; GET YOUR TMA ON AND OFF IN A COUPLE OF MINUTES
  - ALSO A UNIQUE LEVEL SYSTEM IS ADDED TO ADJUST IT PERFECTLY HORIZONTAL

THE FIRST MASH TMA THAT PASSED THE TD 49/07 TEST WITH 70MPH FOR THE UK.





# MASH TESTED, PASSED, FHWA ELIGIBLE AND DOT APPROVED

## WHY BLADE AND HOW IT WORKS

Let's explain how this patented invention works. The TMA strength comes out of the composite aluminum welded profiles, this machine has 12 internal blades. During an impact the first 4 blades cut through the aluminum composite H-beams and after unlocking 8 blades cut through the welded tubes. The remaining weak aluminum parts will bend away in safe directions. The patent is based on cutting aluminum H beams and tubes using BLADES.

- NO.1 MASH TMA
- MODULAR & REPAIRABLE
- NO.1 ON INCREDIBLE TEST RESULTS
- HIGHEST SAFETY LEVEL TMA

# PROUDLY TESTED IN THE U.S.A.

THE FIRST AND ONLY TMA WITH  
ALL CRASH TEST MOVIES SHOWN  
PUBLIC



INCLUDING  
THE CABIN  
CONTROL  
UNIT



# THE 39 CRASH TESTS



## No.1 ON RESULTS

This patented BLADE TMA is proudly full scale crash tested according MASH 2016 at the Texas Transportation Institute (TTI), with unbelievable test results! All the ride down values were within the preferred values

(MASH preferred a Longitudinal ridedown of 15.0 g with a maximum of 20.49 G ). The BLADE TMA is also full scale crash tested according the UK optional 110Kph test TD49/07.

## THIS IS WHY!

THIS TMA HAS THE HIGHEST SAFETY LEVEL! THIS PATENTED BLADE TMA IS PROUDLY FULL SCALE CRASH TESTED ACCORDING MASH 2016







CONVOY  
VEHICLE  
NO  
OVERTAKING

FM17  
ZUC



# THE No.1 MASH TRUCK MOUNTED ATTENUATOR

**MASH TESTED, PASSED, FHWA ELIGIBLE AND DOT APPROVED**

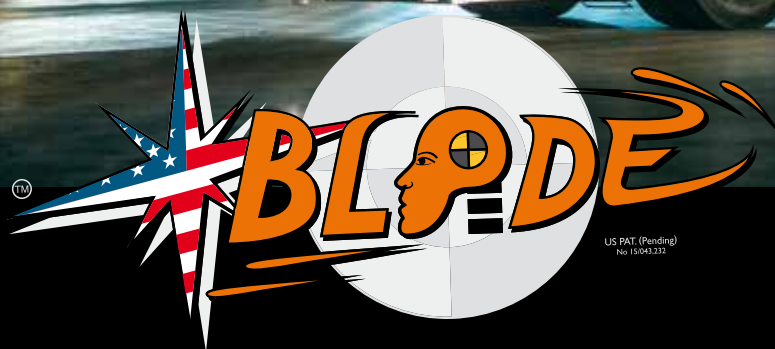

**WWW.BLADE-TMA.COM**

The first in the world with test results within the preferred MASH values